

Technical Data Sheet

Date: 03/11/2022

5x32A CEE Norm Plug

Ref. No: 3108-301-1600



Pack Unit

5



Weight

292 gr.



Technical Informations

Ampere	32A
Voltage	380 - 415 V. AC
Hertz	50 - 60 Hz
Protection Class	IP 67
Clock Postion	6h
Number Of Poles	5 (3P + N + E)
Contact Material	Brass (CuZn)
Housing Material	PA6
Connection Type	Screw
Operation Temp.	-25 / +80 (1 hour -100° C)
	(-25 / + 40 IEC 60309)

Dimensions

a	156
b	107
c	102
Ød	11-20,5
Cable Diameter (Min.)	2,5 mm ²
Cable Diameter (Max.)	10 mm ²

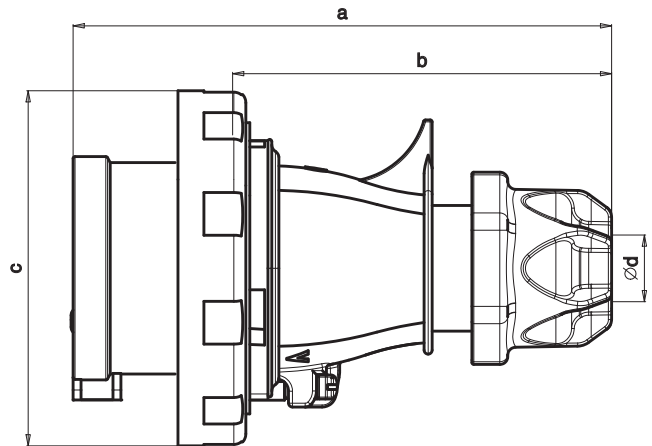

Different Earth Contact Positions (Clock Positions)

3108-301-1100-2h	3108-301-1600-3h	3108-301-0700-4h	3108-301-0300-5h	3108-301-1600	3108-301-0300-7h	3108-301-0900-9h	3108-301-1600-11h



Tel: +90 232 880 90 01
Fax: +90 232 880 90 02



info@tpelectric.com.tr



Kemalpaşa O.S.B. 600 Sk. No:364
35730 Kemalpaşa - İZMİR / TÜRKİYE