

Perforación para Montaje

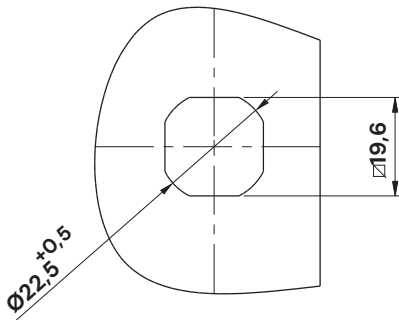

DATOS TÉCNICOS

Suministro:

Casquillo, tuerca y cilindro inyectados en zamak. Seis discos de ajuste y lengüeta abultada de **acero con un espesor de 1,5 mm.**

Acabado:

Cromado o pintado de negro. Tuerca, lengüeta y discos de ajuste galvanizados trivalente blanco.

Montaje:

Es necesario desmontar la lengüeta. Fijación mediante tuerca (par de apriete recomendado: 2 a 2,5 N/m.). Los discos permiten ajustar la altura de la lengüeta.

	MEDIDA DE LA LENGÜETA CON AJUSTE (A)	 CILINDRO TRIANGULAR	 CILINDRO CUADRADO	 CILINDRO UNIVERSAL 3 mm	 CILINDRO CASTILLO	 CILINDRO RANURA
CROMADO	15 a 24 mm	23452	23472	23492	23414	23404
	20 a 29 mm	23424	23434	23444	23464	23454
	25 a 34 mm	23422	23442	23432	23412	23482
	30 a 39 mm	23474	23484	23494	23416	23406
	35 a 44 mm	23426	23436	23446	23466	23456
NEGRO	15 a 24 mm	23451	23471	23491	23413	23403
	20 a 29 mm	23423	23433	23443	23463	23453
	25 a 34 mm	23421	23441	23431	23411	23481
	30 a 39 mm	23473	23483	23493	23415	23405
	35 a 44 mm	23425	23435	23445	23465	23455